

# Occhio

Montageanleitung  
*Mounting instructions*

ìO  
alto v

## Produktbeschreibung

LED Deckenstrahler als downlight mit kugelförmigem Kopf und Linsenoptik. Version für Aufputzmontage, Anschluss an 230 V AC Netzspannung, dimmbar via Phasenabschnittdimmer\*.

Lichtwirkung durch optionale inserts jederzeit über einen einfachen Mechanismus veränderbar. VOLT light engine wechselbar.

\* Liste kompatibler Dimmer:  
[www.occhio.de/dim](http://www.occhio.de/dim)

## Product description

LED ceiling spotlight as a downlight with spherical head and lens optics. Version for mounting on plaster surfaces; connection to 230 V AC mains voltage; dimmable via trailing-edge phase-cut dimmer\*.

Lighting effect through optional inserts can be changed at any time using a simple mechanism. The VOLT light engine light module is replaceable.

\* For a list of compatible dimmers, see  
[www.occhio.de/dim\\_en](http://www.occhio.de/dim_en)

# Linse und inserts einsetzen

## Inserting lens and inserts

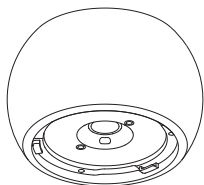

head



Blende\*/aperture\*



soft edge Glas\*  
soft edge glass\*



satinirtes Glas  
satinised glass



fresnel Linse  
fresnel lens



Linse  
lens

\* Im Lieferumfang enthalten  
\* Included in the scope of delivery

Linse entnehmen  
Remove lens

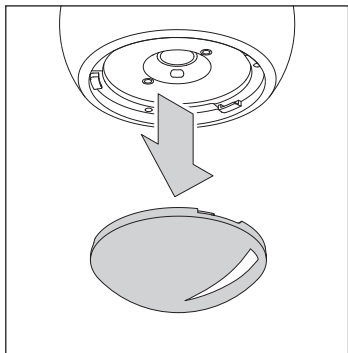
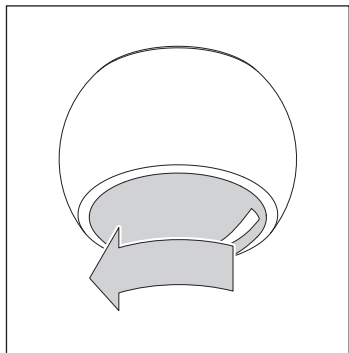
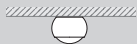

Linse einsetzen  
Inserting lens

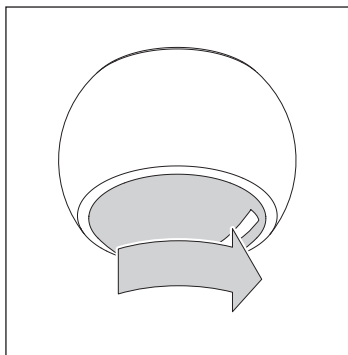
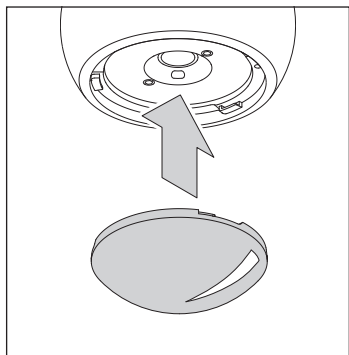

Inserts einsetzen (optional)  
Inserting inserts (optional)

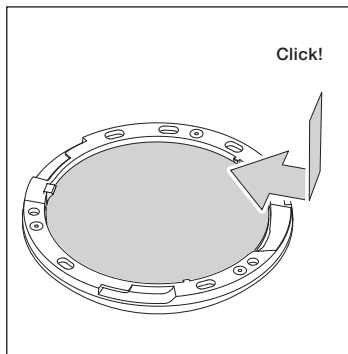
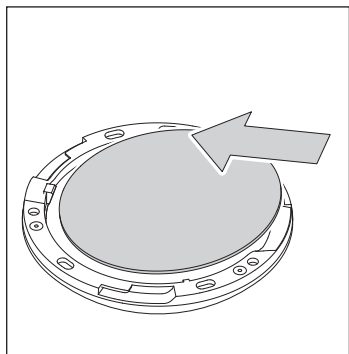
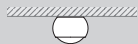

Inserts entnehmen (optional)  
Remove inserts (optional)

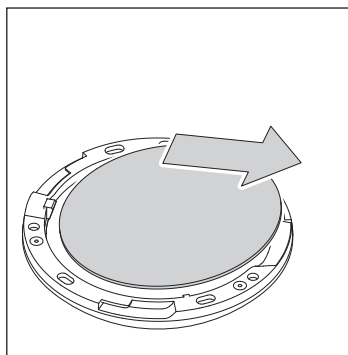
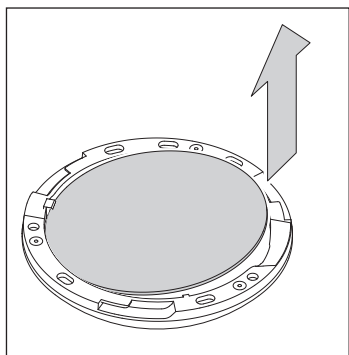

Blende einsetzen (optional)  
Inserting aperture (optional)

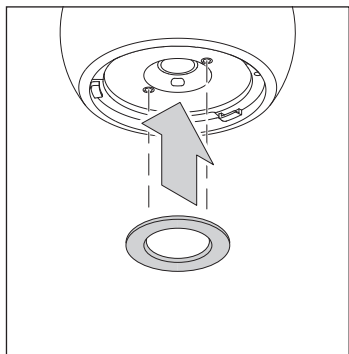
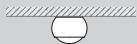

**Blende nur ohne inserts verwenden.**  
Use aperture just without inserts.

Blende entnehmen (optional)  
Remove aperture (optional)

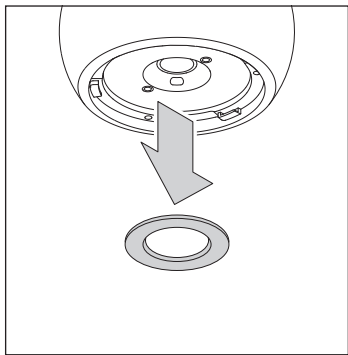
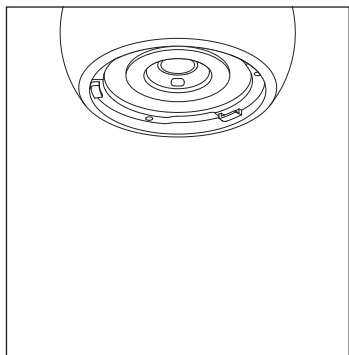

# Montage io alto v Mounting io alto v

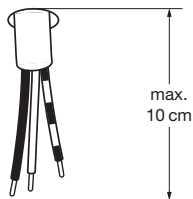

bei Durchverkabelung max. 5 cm  
with through-wiring max. 5 cm

2x $\varnothing$ 6 mm

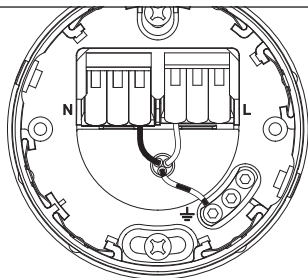
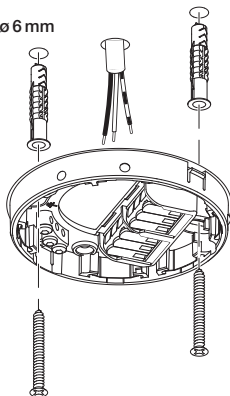

Netzkaabel wie dargestellt  
anschiessen.  
Connect the mains cable as shown.

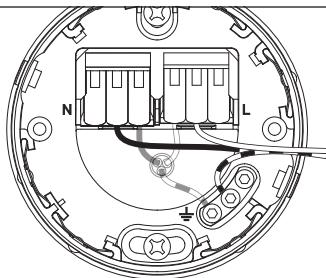

Kabel der Leuchte wie dargestellt  
anschiessen.  
Connect the luminaire's cable as  
shown.

# Montage io alto v

## Mounting io alto v

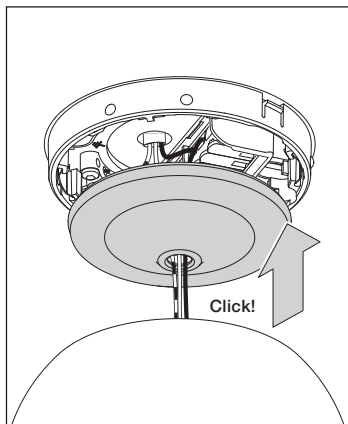

Das cover aufsetzen.  
Put on the cover.

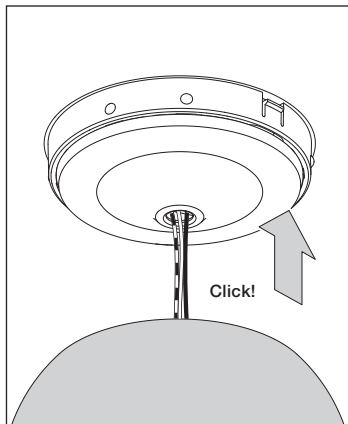

Head auf base aufsetzen.  
Put on the head to base.



**Achtung!**  
**Vor der Montage alle stromführenden Leitungen vom Stromnetz trennen!**



**Caution!**  
**Before mounting, disconnect all current-carrying lines from the mains supply!**



# Montage io alto v

## Mounting io alto v

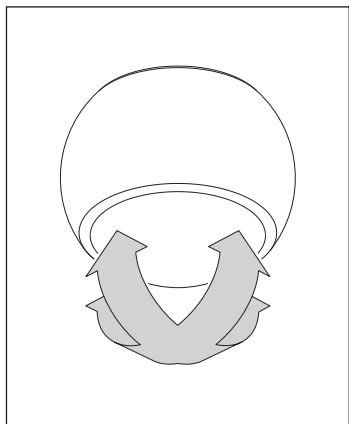

Festen Halt der Leuchte überprüfen!

**Die Leuchte ist nun fertig montiert.**

Check that the luminaire is held in place firmly.

**The luminaire is now fully mounted.**



**Achtung!**  
**Keine Kabel bei der Befestigung einklemmen!**



**Caution!**  
**When mount make sure not to jam any cables!**



Occhio GmbH  
Wiener Platz 7  
81667 München  
Fon +49-89-44 77 86 30  
Fax +49-89-44 77 86 39  
info@occhio.de  
www.occhio.de

## Demontage io alto v Remove io alto v

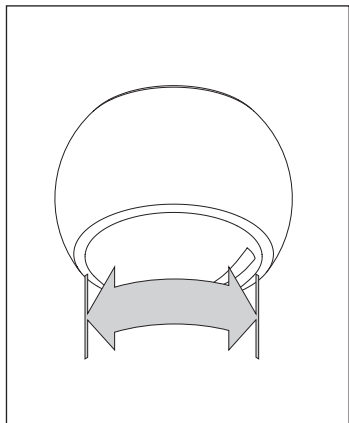

Die montierte Leuchte bis zum Anschlag in eine Richtung drehen.

Turn the mounted luminaire in one direction till it stop.



**Achtung!**  
**Vor der Demontage alle stromführenden Leitungen vom Stromnetz trennen!**

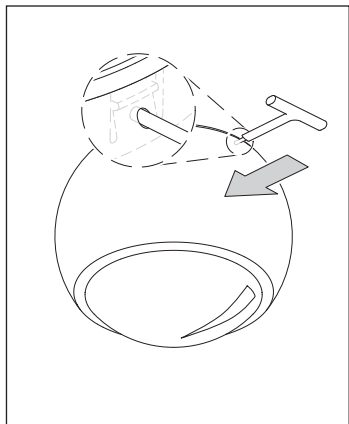

Anschließend mit dem Release-Tool den Verriegelungsmechanismus nach hinten drücken und ...

Afterwards press the locking mechanism by release tool backwards and ...



**Caution!**  
**Before dismantling, disconnect all current-carrying lines from the mains supply!**

# Demontage io alto v

## Remove io alto v

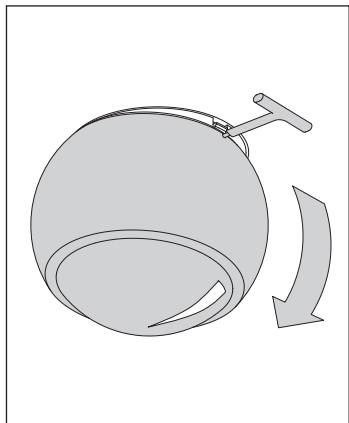

... die Leuchte nach vorn neigen.

... tilt the luminaire to the front.



**Achtung!**  
Bei der Entnahme keine Kabel  
abreißen.



**Caution!**  
Do not tear off any cables when  
removing.

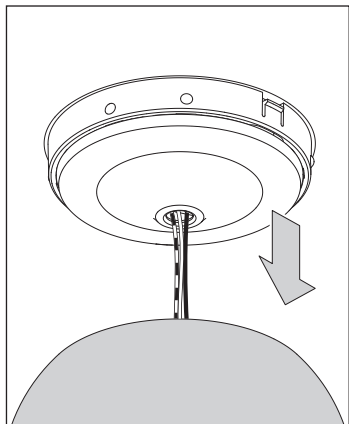

Leuchte von der base entnehmen.

Remove luminaire from base.



**Achtung!**  
Die Oberfläche der Leuchte kann  
im Dauerbetrieb heiß werden.



**Caution!**  
When used in continuous  
operation, the surface of the  
luminaire can become hot.



## Pflegehinweise Care instructions

Leuchte nur in abgekühltem  
Zustand reinigen!

Zur Reinigung der Leuchte ein  
trockenes Mikrofasertuch oder  
das Occhio Reinigungsmittel  
verwenden.

Always allow the luminaire to cool  
down before cleaning.

To clean the luminaire, use a dry  
microfibre cloth or the Occhio  
cleaning agent.

## Info & Kontakt Information & contact







Weitere Fragen beantwortet gerne  
Ihr Occhio Fachhändler

Your Occhio specialist retailer will  
gladly answer any other questions

**[www.occhio.de](http://www.occhio.de)**  
**[info@occhio.de](mailto:info@occhio.de)**

# Technische Daten

## Technische Daten Leuchte

Artikelbezeichnung	Occhio io alto v VOLT
Abmessungen head	ø 100 mm, H 80 mm (inkl. Linse)
Schutzklasse	1
Anschluss	230 VAC, 50 Hz
Dimmung	via Phasenabschrittdimmer (Liste kompatibler Dimmer: <a href="http://www.occhio.de/dim">www.occhio.de/dim</a> )
Material Leuchte	Aluminium verchromt, lackiert oder eloxiert, Kunststoff
Material Inserts	Glas, optischer Kunststoff
LED-Leistung	13 W
Zulässige Betriebsbedingung	max. 30°C nur im Innenbereich betreiben
Prüfzeichen	IP 20 CE       

## Technische Daten Leuchtmittel

Leuchtmittel	VOLT light engine
Ausführung	LED-Modul (wechselbar)
Lebensdauer	> 40.000 Std.
Energieeffizienzklasse – EEK	A

## Entsorgung

Bei örtlicher Entsorgungsstelle entsorgen. Das Leuchtmittel ist recyclebar; RoHS-konform. **Nicht in den Hausmüll geben!**

# Technical data

## Technical data luminaire

Product designation	Occhio io alto v VOLT
Dimensions head	ø 100 mm, H 80 mm (incl. lens)
Safety class	1
Connection	230 VAC, 50 Hz
Dimming	by trailing-edge phasecut dimmer (For a list of compatible dimmers, see <a href="http://www.occhio.de/dim_en">www.occhio.de/dim_en</a> )
Luminaire material	aluminium – chrome-plated, painted or anodised, plastic
Inserts material	optical plastic, glass
LED power	13 W
Permitted operating conditions	max. 30°C for indoor use only
Test symbols	<b>IP 20</b>      

## Technical data light source

Light source	VOLT light engine
Version	LED module (replaceable)
Lifetime	> 40,000 h
Energy efficiency class – EEC	A

## Disposal

Dispose of at the local waste disposal site. The light source is recyclable and RoHS-compliant. **Do not dispose of with household waste.**



# Sicherheitshinweise

Lesen Sie die Montage-/Gebrauchsanweisung sorgfältig durch, bevor Sie die Leuchte installieren. Beachten Sie die Sicherheitshinweise in dieser Anleitung genau und bewahren Sie die Anleitung auf.



Die Montage von Elektrokomponenten darf nur von qualifiziertem Fachpersonal durchgeführt werden. Reparaturarbeiten dürfen nur von autorisiertem Fachpersonal oder dem Hersteller durchgeführt werden. Vor allen Arbeiten am Strahler (Installation, Leuchtmittelwechsel, Reinigung etc.) diesen unbedingt vom Stromnetz trennen.



Sicherheitsabstand zu brennbaren Objekten einhalten: 20 cm!



Dieses Zeichen macht Sie auf heiße Oberflächen aufmerksam, deren Berührung Verbrennungen zur Folge haben können. Achtung: Die Oberfläche des Strahlers kann nach längerer Betriebsdauer heiß sein! Vor allen Arbeiten am Strahler (Montage des Strahlers, Wechsel des Leuchtmittels, Wechsel der Inserts, usw.), Strahler immer ausschalten und mindestens 30 Minuten abkühlen lassen. Nur zur Installation außerhalb des Handbereichs vorgesehen.

## Safety precautions

Read through the mounting/use instructions carefully before installing the luminaire. Follow the safety precautions in these instructions closely and keep the instructions in a safe place.



The assembly and installation of electrical components must be carried out only by qualified personnel. Repairs must be carried out only by authorised, qualified personnel or the manufacturer. Before performing any work on the luminaire (installation, changing the light source, cleaning, etc.), it must be disconnected from the mains supply.



Maintain the minimum safety distance from flammable materials: 20 cm.



This symbol warns you of hot surfaces, which could cause burns if touched. Caution: When used for prolonged periods, the surface of the luminaire can become hot. Before performing any work on the luminaire (fitting the luminaire, changing the light source or insert, etc.), always switch the luminaire off and let it cool for at least 30 minutes. Only for installing in a position which is out of arm's reach.