

# LANTERN! TABLE LAMP

## A, Introduction

- Before you go in any manipulation with the appliance, please read carefully this direction, and observe all instructions and recommendations!
- The lighting assembly must be made with more persons than one.
- It is forbidden to use the product for the purpose other than intended, and contrary to this direction, and that for safety reasons and for the reason of the guarantee termination.
- Switch off power at main circuit panel prior to installation!
- Any electric installation, including putting the appliance into operation, may be performed by a qualified electrician only.
- Prevent children and persons with lowered sensual and mental capabilities to manipulate with the lighting fitting since the product consists of tiny and fragile components that may be dangerous for them at manipulation or in case of ingestion.
- The manufacturer assumes no liability for damage resulting from incorrect installation.
- The pendant light is intended for the illumination of interior or home accommodation.

## B, Product name: Table lamp LANTERN

- The table lamp LANTERN is available in one size in dimensions as indicated below.
- The lamp shade is hand-blown from clear crystal material.
- The product is intended for the illumination of interior (dry environment only).

## C, Components included with unit

- Hand-blown crystal lamp shade
- Powder coating base fitting (available in black or white colours)
- Installation Instructions, Letter of guarantee
- Cleaning and Maintenance Manual
- Gloves

Light source and fixing material are not part of the lighting fixture kit.

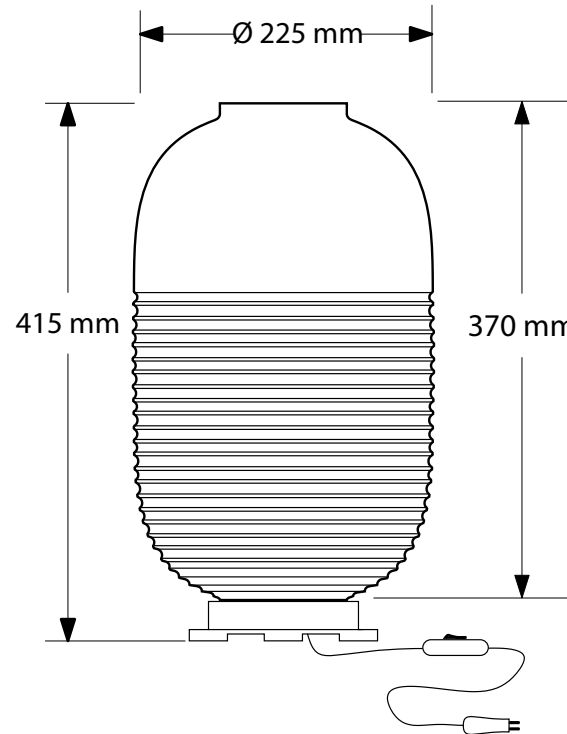

## D, Assembly and Disassembly - connecting to and disconnecting from the network

- After unpacking, first of all, check for damage during the transport and for completeness. If anything is wrong, contact your dealer immediately since later complaint for the above reasons would not be accepted.
- Perform the assembly of the appliance with the use of schematic drawing, respecting that the electric installation and connection to the network may be performed by an electrician with proper qualifications only, while observing general regulations as well.
- Use the appropriate source on the bulb sleeve (1). In order to put a new bulb into a lighting fixture's socket, turn the bulb in a clockwise direction.
- Insert the crystal part (2) to the bottom fitting (3).
- At disassembly, first switch the lighting fitting off, and disconnect it from the power.
- Then you may proceed in a similar way, in the opposite order than at the assembly.
- Any transport of the appliance later should be performed either in the original wrap or similar in order to avoid damage.
- Technical support: [info@bomma.cz](mailto:info@bomma.cz)

## E, Technical specification, purpose

- Nominal voltage: 230 V/ A.C. 50Hz
- Protection: IP 20
- Nominal input: 1x 40 W (E27)
- Class: II.
- Weight of crystal part: (approx.) 3,5 kg

Bohemia Machine s.r.o.  
Zámecká 1177  
58291 Světlá nad Sázavou  
Czech Republic

+420 569 453 149  
info@bomma.cz  
www.bomma.cz

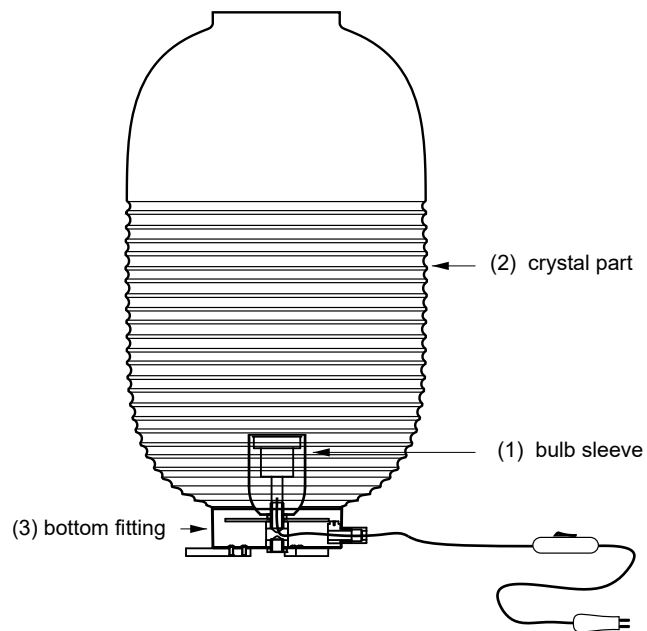

pic. 1

## Recommended energy - saving LED E27.

## F, Liquidation

After the end of the technical life span of the appliance, before its liquidation, disconnect it from the electric cord, dismount it and separate the individual parts. The sorted out waste material should be delivered to the organization authorized to liquidate

ID	Category	Title
10 11 11*	N	Small particles of waste glass and glass powder containing heavy metals included PbO
10 11 12	O	Waste glass other than no. 10 11 11 (sodium-potassium glass)
17 04 01	O	Copper, bronze, brass
17 04 05	O	Iron and steel
20 01 01	O	Paper and pasteboard
15 01 05	O	Package with plastic insert