

CERCLE & TRAIT

D'une apparente légèreté, les formes de *Cercle & trait* se frottent et se tiennent dans un jeu d'équilibre savamment dosé. Une suspension graphique déclinée en différentes finitions qui ne tient qu'à un fil.

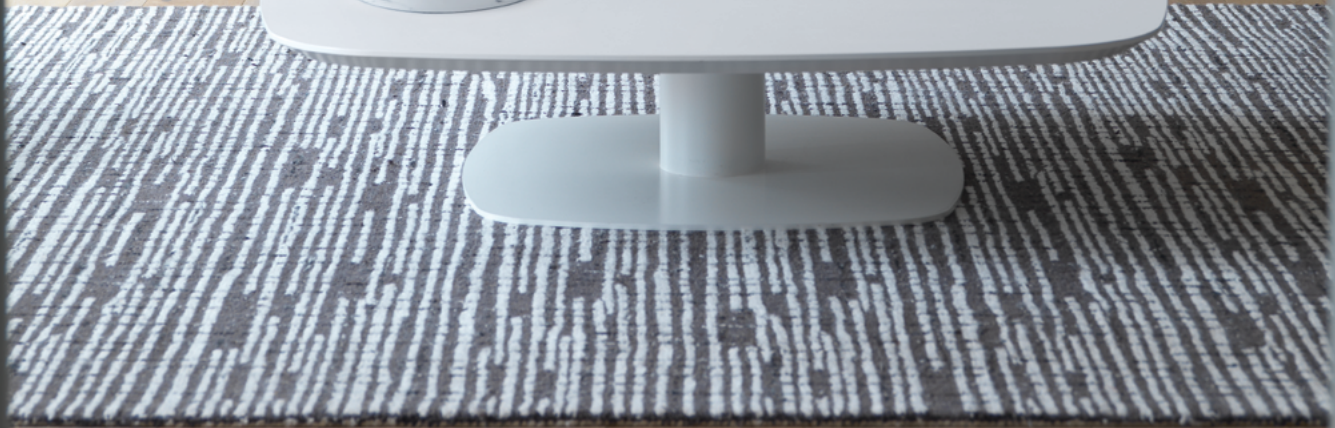

As light as it looks, the forms of *Cercle & trait* rub together and hold together in a cleverly measured balance. A graphic pendant, available in different finishes, is just held by one small wire.

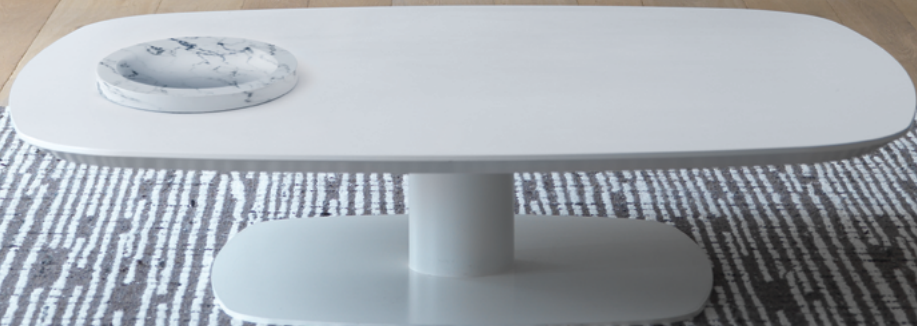

**Finitions
Finishes**

● Laiton satiné
SB Satin brass

● Graphite satiné
SG Satin graphite

● Nickel satiné
SN Satin nickel

● Cuivre satiné
SC Satin copper

**Matériaux
Material**

Laiton massif
Solid Brass

Diffuseur en polycarbonate blanc
White polycarbonate diffuser

Câble textile noir (longueur ≈ 1 m)
Black textile cable (length ≈ 39.4")

**Source
Lamping**

LED 1400 lm 2700°K
LED 1400 lm 2700°K

Alim. 24V intégrée dans le pavillon
Int. power supply 24V included in canopy

Variable (phase cut)
Dimmable (phase cut)



Designer

POOL

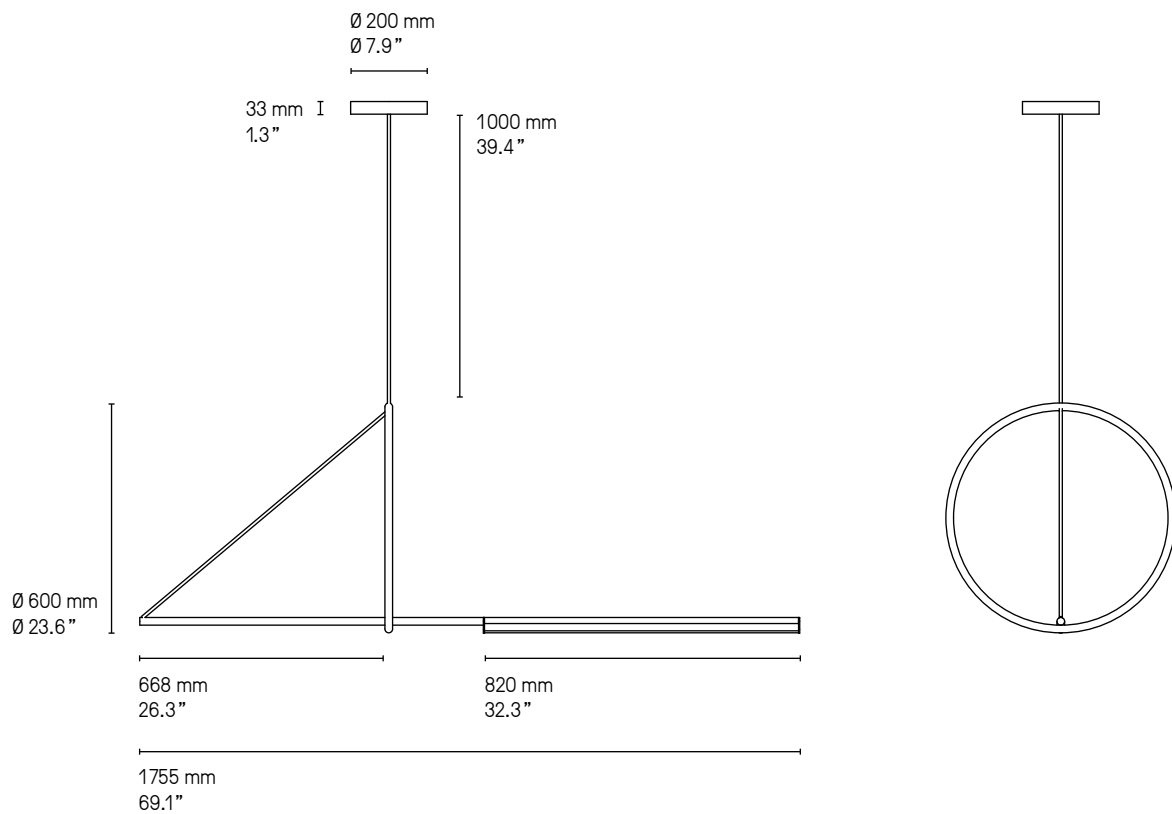



Cercle & trait SG

NUANCIER - FINISH OPTIONS



LAITON - BRASS

- | | |
|-------------------------------------|---|
| ① Laiton satiné
SB Satin brass | ② Graphite satiné
SG Satin graphite |
| ③ Nickel satiné
SN Satin nickel | ④ Cuivre satiné
SC Satin copper |
| ⑤ Laiton poli
PB Polished brass | ⑥ Graphite poli
PG Polished graphite |
| ⑦ Nickel poli
PN Polished nickel | ⑧ Cuivre poli
PC Polished copper |

ABAT-JOURS - LAMPSHADES



Drop Paper® 100



Drop Paper® 101

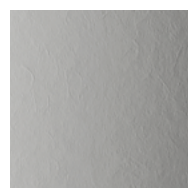

Drop Paper® 103

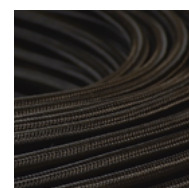

Tissu noir
Black textile



Chinette blanche
White chinette

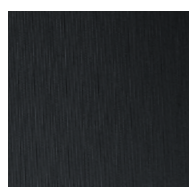

Chinette noire
Black chinette

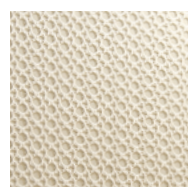

Duke
Duke



Tissu or
Gold textile

VERRERIE - GLASS



Opale
Opal

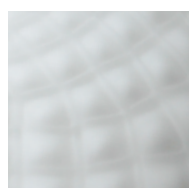

Opale et écaïlle
Opal and patterned



Claire et écaïlle
Clear and patterned

CONSEILS TECHNIQUES

Les caractéristiques techniques mentionnées dans ce document sont données à titre indicatif et sont susceptibles de subir des modifications. Ceci est lié à l'évolution rapide de la technologie LED.

Les dimensions sont approximatives et peuvent varier légèrement.

AMPOULES

Il est impératif de respecter les types et les puissances maximales préconisées sous peine de détériorer le luminaire. En cas de non-respect, la garantie ne pourra s'appliquer.

CONSEIL D'ENTRETIEN

Essuyage avec un chiffon doux, sans produits d'entretien. Nos produits étant vernis afin d'assurer la longévité du luminaire, il ne faut en aucun cas utiliser de produits détergents ou de solvants.

La société se réserve le droit de modifier, sans préavis, les caractéristiques de ses produits.

TECHNICAL ADVICE

The technical characteristics provided in this document are for information purposes only and are subject to change, due to permanent evolution of LED technology.

All dimensions are approximate and may vary slightly.

LIGHT BULBS

Use only the type of light bulb and maximum wattage shown otherwise you may damage the light fitting. Failure to use the correct light bulb and wattage will affect the warranty.

CARE INSTRUCTIONS

Wipe with a soft cloth –do not use any cleaning products. All our light fittings are lacquered to ensure the longevity of the product– under no circumstances use detergents or solvents.

The company reserves the right to modify its products at any time without notice.

CVL LUMINAIRES

79 ROUTE DE LA CHEVALLERIE – 49770 LONGUENÉE-EN-ANJOU – FRANCE

TEL. +33 (0) 2 41 32 67 54 – FAX +33 (0) 2 41 32 76 62

EMAIL : CONTACT@CVL-LUMINAIRES.FR

WWW.CVL-LUMINAIRES.FR